

<b>Electrical Characteristics</b>										
Frequency	Hz	50				60				
Voltage (series star)	V	380	400	415	440	415	440	460	480	
Rated power class H	kVA	125	125	125	105	130	140	150	150	
	kW	100	100	100	84	104	112	120	120	
Rated power class F	kVA	113	113	113	95	116	125	136	136	
	kW	90,4	90,4	90,4	76	92,8	100	109	109	
Regulation with UVR6		±1% with any power factor and speed variations between -5% +30%								
Insulation class		H								
Execution		Brushless								
Stator winding		12 ends								
Rotor		with damping cage								
Efficiencies class H	4/4	%	92,7	92,8	92,5	92,3	93,8	94,3	94,4	94,5
(see graph. for details)	3/4	%	92,9	93,2	93,1	92,8	94,4	94,6	94,7	94,9
	2/4	%	91,3	91,4	91,4	91,2	92,8	92,9	93	93,1
	1/4	%	88,2	88	87,8	87,8	89,2	89,2	89,2	89
Reactances (f. l.cl. F)	Xd	%	227,1	205	190,4	142,3	237,7	227,7	223,2	205
	Xd'	%	18,3	16,5	15,3	11,5	19,1	18,3	18,0	16,5
	Xd''	%	7,2	6,5	6,0	4,5	7,5	7,2	7,1	6,5
	Xq	%	156,7	141,4	131,4	98,2	163,9	157,1	154,0	141,4
	Xq'	%	156,7	141,4	131,4	98,2	163,9	157,1	154,0	141,4
	Xq''	%	31,8	28,7	26,7	19,9	33,3	31,9	31,2	28,7
	X <sub>2</sub>	%	19,6	17,7	16,4	12,3	20,5	19,7	19,3	17,7
	X <sub>0</sub>	%	3,1	2,8	2,6	1,9	3,2	3,1	3,0	2,8
Short Circuit Ratio	Kcc		0,41	0,51	0,63	0,98	0,32	0,37	0,41	0,51
Time Constants	Td'	sec.	0,0372							
	Td''	sec.	0,0076							
	Tdo'	sec.	1,80							
	Tα	sec.	0,0163							
Short Circuit Current Capacity		%	>300				>350			
Excitation at no load	Amp.		0,5	0,55	0,6	0,8	0,2	0,3	0,4	0,5
Excitation at full load	Amp.		2,2	2,3	2,4	2,6	2	2,2	2,3	2,4
Overload (long-term)		%	1 hour in a 6 hours period 110% rated load							
Overload per 20 sec.		%	300							
Stator Winding Resistance (20°C)	Ω		0,018							
Rotor Winding Resistance (20°C)	Ω		3,165							
Exciter Resistance (20 °C)	Ω		Rotor : 0,410				Stator : 15,28			
Heat dissipation at f.l.cl.H	W		7875	7759	8108	7008	6874	6770	7119	6984
Telephone Interference			FHT < 2%				TIF < 40			
Radio interference			EN50081-1; EN50082-1; VDE0875K. For others standards apply to factory							
Waveform Distors.(THD) at f. load	LL/LN %		1,8 / 1,9							
Waveform Distors.(THD) at no load	LL/LN %		2,4 / 2,5							
<b>Mechanical characteristics</b>										
Protection			IP 21 ( other protection on request )							
DE bearing			6314.2RS							
NDE bearing			6311.2RS							
Weight of wound stator assembly	kg		142							
Weight of wound rotor assembly	kg		90							
Weight of complete generator	kg		431							
Maximun overspeed	rpm		2250							
Unbalanced magnetic pull at f.l.cl.F	kN/mm		5,4							
Cooling air requirement	m <sup>3</sup> /min		19,3				23			
Inertia Constant (H)	sec.		0,102				0,122			
Noise level at 1m/7m	dB(A)		79 / 65				83 / 69			

**50 Hz**

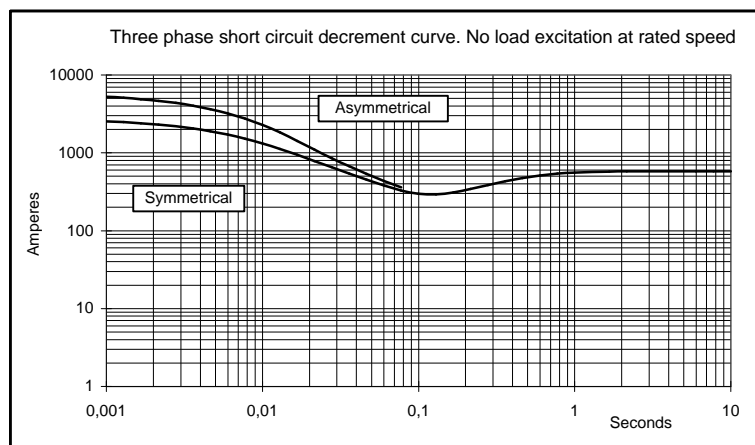

**60 Hz**

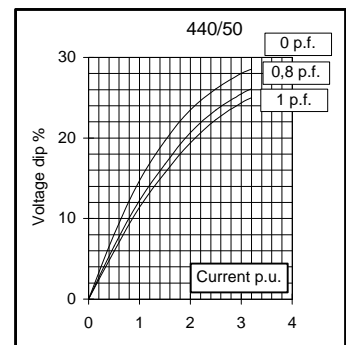
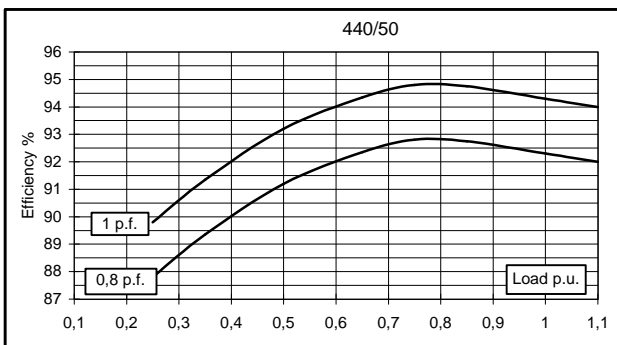
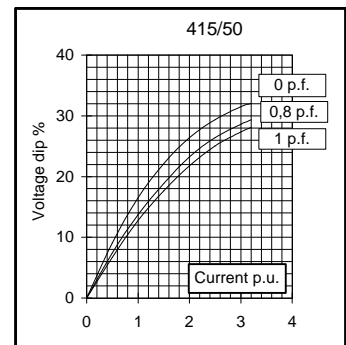
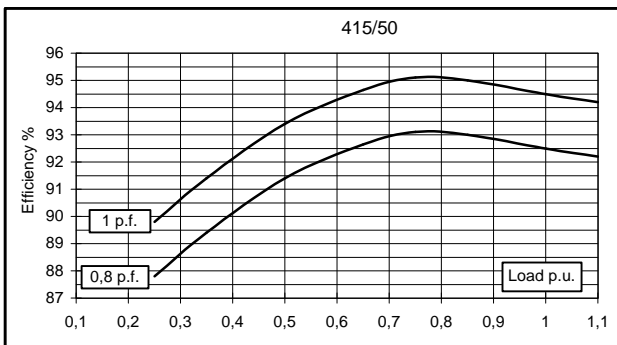
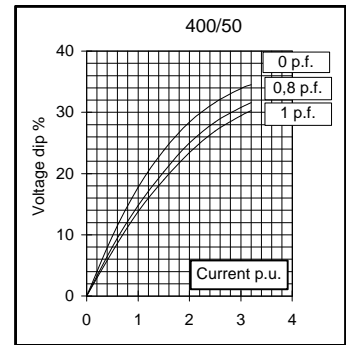
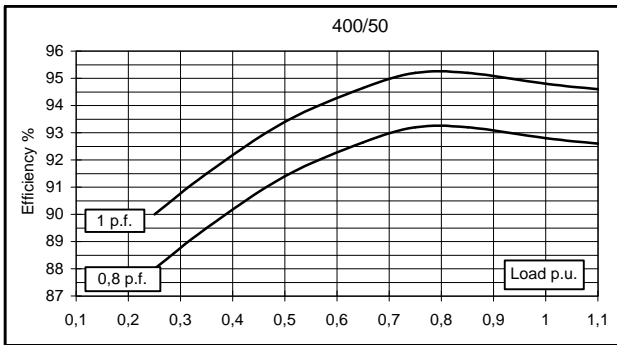
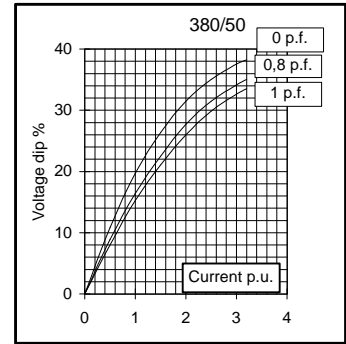
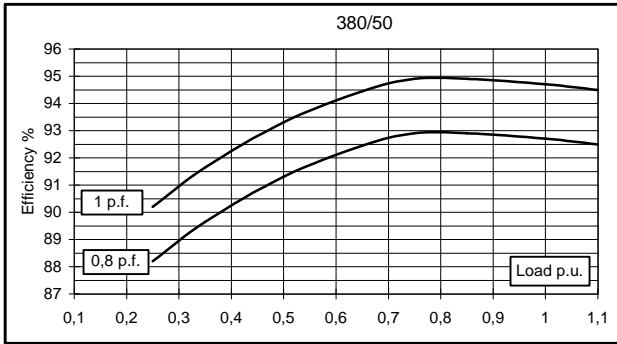
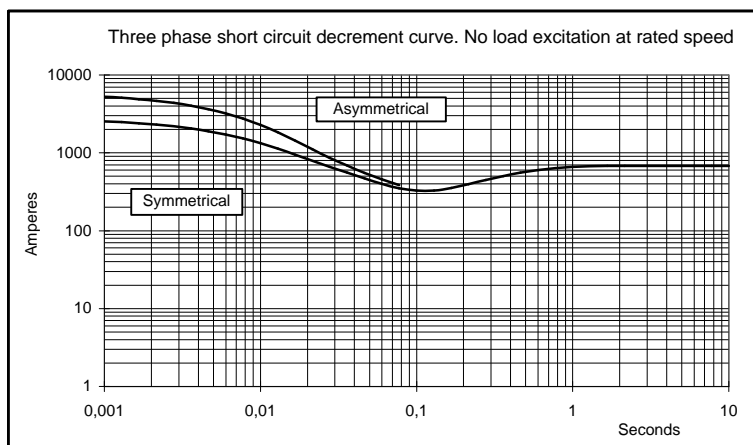
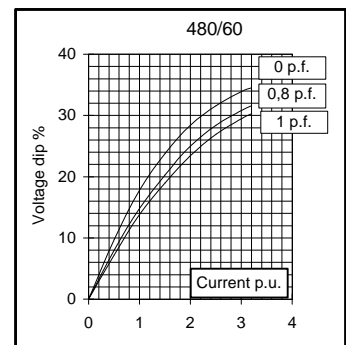
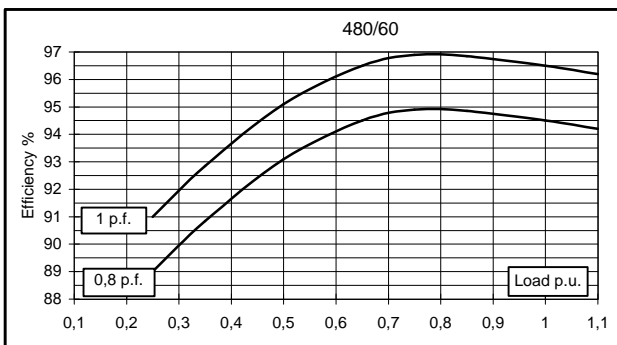
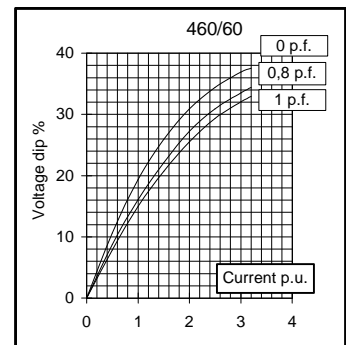
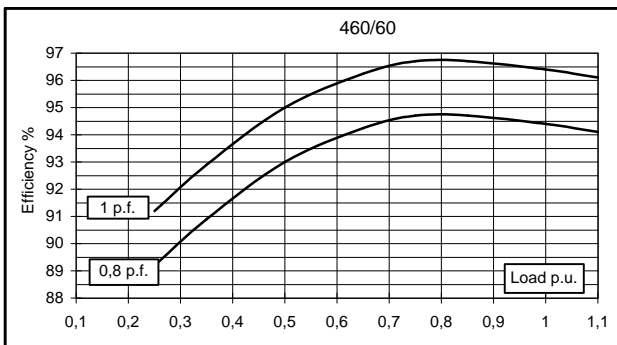
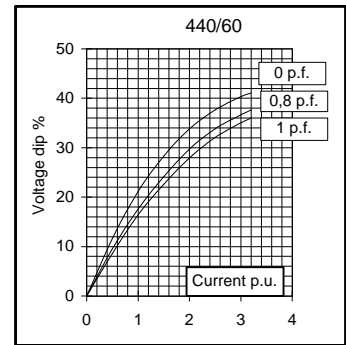
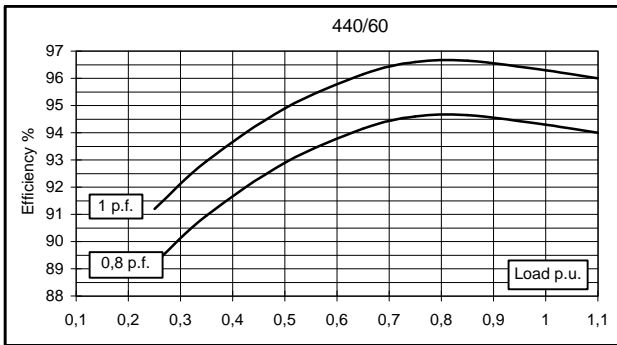
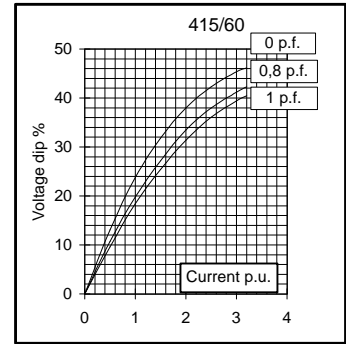
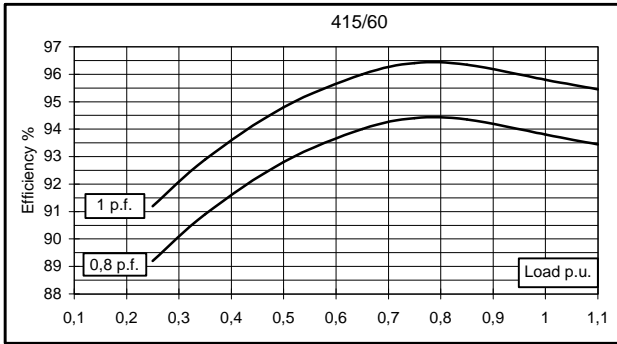

## TWO BEARING MOMENTS OF INERTIA

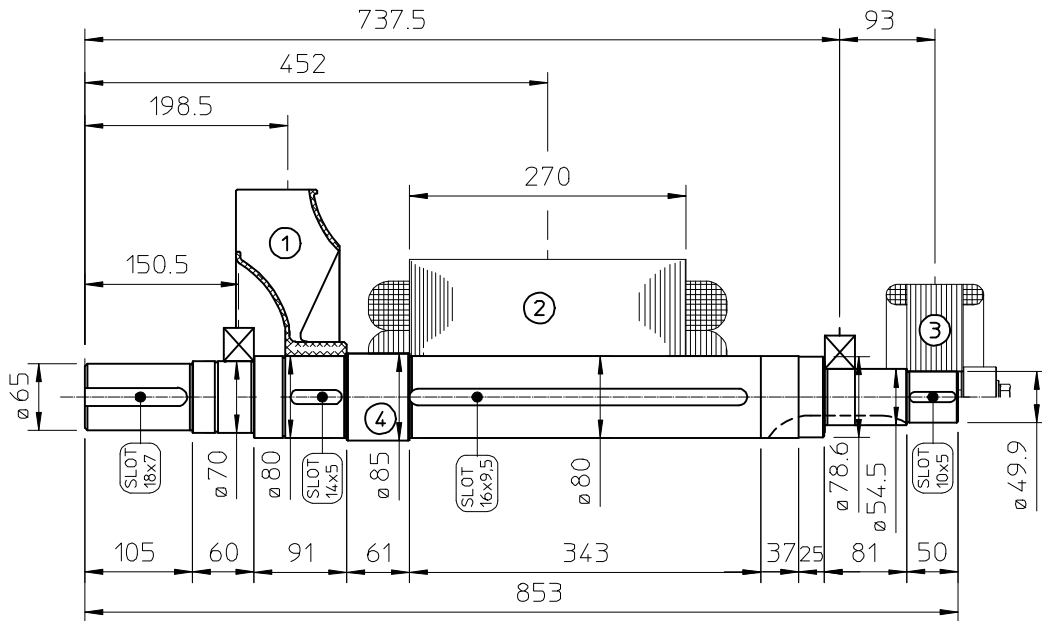

COMPONENT	WEIGHT kg	J kgm <sup>2</sup>
1 FAN	3,3	0,0451
2 MAIN ROTOR	90	0.8772
3 EX. ROTOR	14,5	0,0874
4 SHAFT	28,1	0.0211
TOTAL	135.9	1.0308

## TWO BEARING DIMENSIONS

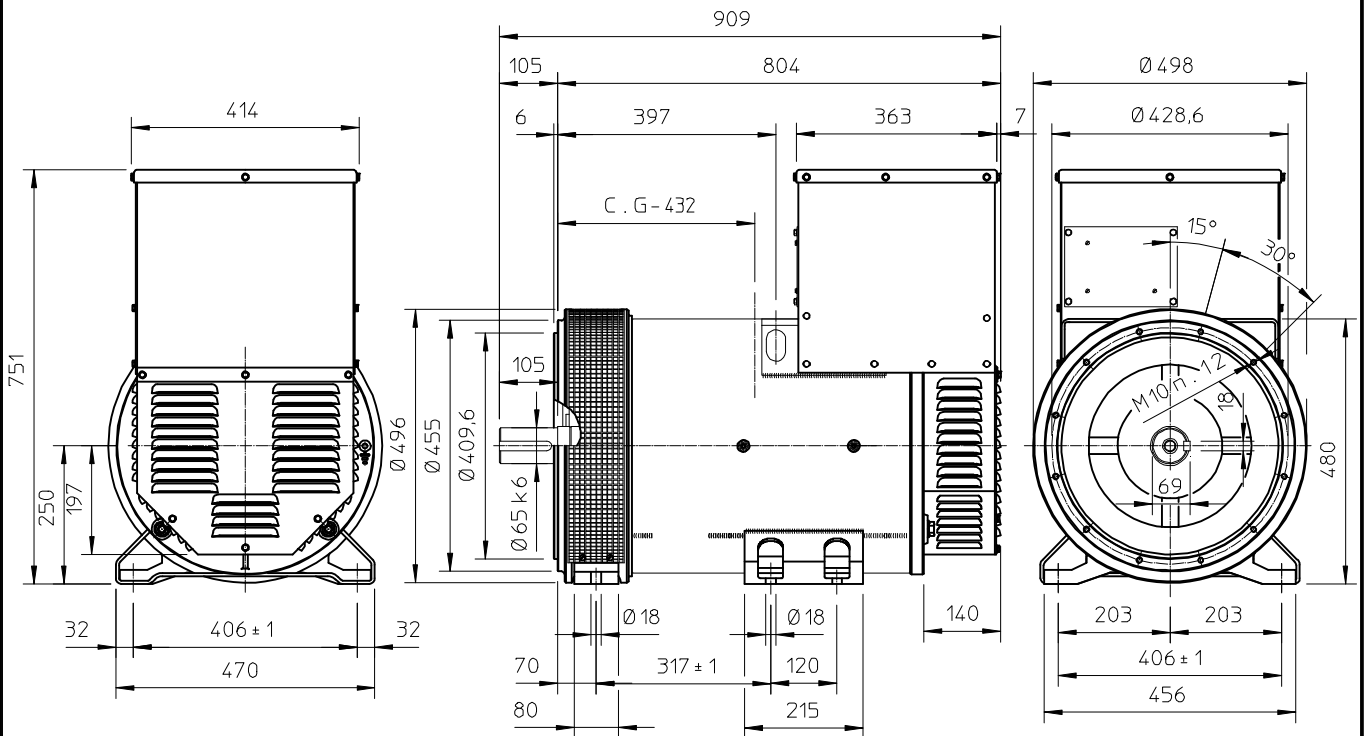

C G - GRAVITY CENTER

